



**Turnichetul**.ro

**Electromechanical  
box tripod turnstile  
with two built-in  
readers**



**TB-01**

**Assembly &  
Operation Manual**



**TB-01**  
**Electromechanical**  
**Box Tripod**  
**Turnstile**  
**with two built-in readers**

Assembly and  
operation manual

CONTENTS

**1. APPLICATION..... 3**

**2. OPERATION CONDITIONS..... 3**

**3. TECHNICAL SPECIFICATIONS..... 3**

**4. STANDARD DELIVERY SET..... 4**

**5. OPTIONAL EQUIPMENT SUPPLIED ON REQUEST..... 4**

**6. PRODUCT DESCRIPTION..... 4**

6.1. Main features ..... 4

6.2. Design ..... 5

6.3. Control over the TB-01 turnstile ..... 8

6.4. Input control signals and their parameters at autonomous control ..... 9

6.5. Control modes ..... 11

6.6. Operation from the RC panel ..... 12

6.7. Operation from wireless remote control ..... 13

6.8. Operation from an ACS controller ..... 13

6.9. Optional external devices connected to the turnstile ..... 13

6.10. Unblocking with a mechanical release key..... 14

6.11. Operation contingencies and response..... 14

**7. MARKING AND PACKAGING..... 15**

**8. SAFETY REQUIREMENTS..... 15**

8.1. Installation safety requirements..... 15

8.2. Operation safety requirements ..... 16

**9. INSTALLATION INSTRUCTIONS..... 16**

9.1. Installation details..... 16

9.2. Installation tools..... 17

9.3. Cable length ..... 17

9.4. Installation procedure ..... 17

9.5. Connecting readers to an ACS..... 20

**10. OPERATION INSTRUCTIONS..... 21**

10.1. General..... 21

10.2. Power-up..... 21

10.3. Turnstile operating modes in pulse control mode..... 22

10.4. Operation of the TB-01 turnstile in potential control mode..... 23

10.5. Operation of the turnstile when controlled by an ACS ..... 24

10.6. In case of an emergency ..... 25

10.6.1 Unlocking with a mechanical release key ..... 25

10.6.2 Anti-panic folding arms..... 25

10.7. Possible faults ..... 25

**11. TRANSPORTATION AND STORAGE..... 26**

**12. MAINTENANCE..... 26**

**APPENDIX A..... 28**

**APPENDIX B..... 32**

**APPENDIX C..... 34**

*Dear Customer,*

*Thank you for purchasing a box tripod turnstile manufactured by PERCo. Please follow instructions given in this Manual carefully, and this high quality product will provide many years of trouble-free use.*

The Assembly and Operation Manual (hereinafter – the Manual) contains the instructions you will need for safe transportation, storage, installation, operation and maintenance of the TB-01 electromechanical box tripod turnstile with built-in readers (hereinafter – the turnstile).

The product installation must be carried out by qualified installers in strict accordance with the Manual.

Abbreviations adopted in the Manual:

ACS – access control system;

CLB – control logic board;

RC panel – remote control panel.

## **1. APPLICATION**

- 1.1. The TB-01 electromechanical box tripod turnstile with two built-in readers is designed for pedestrian passage control by proximity cards at entrance points of industrial facilities, banks, administrative buildings, railway terminals, airports, etc.
- 1.2. To ensure fast and convenient passage through the turnstile it is recommended to install one TB-01 turnstile per each 500 persons working same shift, or based on the passage pick of 30 persons per minute (Ref. Section 3 for the throughput rate of the turnstile).

## **2. OPERATION CONDITIONS**

- 2.1. The TB-01 turnstile with regard to resistance to environmental exposure complies with GOST 15150 category NF4 (operation in premises with climate control).
- 2.2. Operation of the TB-01 turnstile is allowed at an ambient air temperature from +1°C to + 40 °C and relative air humidity 80% at +25 °C.

## **3. TECHNICAL SPECIFICATIONS**

|   |                 |
|---|-----------------|
| Operating voltage.....                                | 12±1,2VDC       |
| Power consumption .....                               | max. 20 W       |
| Consumption current.....                              | max. 1,5 A      |
| Throughput rate in a single passage mode. ....        | 30 persons/min. |
| Throughput rate in a free passage mode.....           | 60 persons/min. |
| Passage width.....                                    | 500 mm          |
| Barrier arm rotation force .....                      | max. 3,5 kgf.   |
| Number of readers .....                               | 2               |
| Card reading distance at the rated operating voltage: |                 |
| HID cards .....                                       | min. 6 cm       |
| EM-Marin cards .....                                  | min. 8 cm       |
| RC panel cable length.....                            | min. 6,6 m      |
| RC panel overall dimensions (L x W x H) .....         | 120x80x21 mm    |

## Assembly and Operation Manual

---

|  |                                      |
|--|--------------------------------------|
| RC panel net weight.....   | max. 0,2 kg                          |
| Ingress Protection Rating.....                                     | IP41 under EN 60529                  |
| Electric shock protection class .....                              | III according to GOST R IEC 335-1-94 |
| Mean time to failure .....   | min. 1500000 passages                |
| Mean lifetime.....   | 8 years                              |
| Overall dimensions of the TB-01 with barrier arms (L x W x H)..... | 1050x684x1030 mm                     |
| Net weight of the turnstile .....                                  | max. 68 kg                           |

### 4. STANDARD DELIVERY SET

|   |   |
|---|---|
| Turnstile housing.....  | 1 |
| Barrier arm (separately itemized in the price list, type is chosen by a Client at the time of order)..... | 3 |
| Key to a housing top cover lock.....  | 2 |
| Mechanical release key .....  | 2 |
| Key to a housing side cover lock.....   | 2 |
| RC panel with cable min. 6,6 m long.....  | 1 |
| Jumper.....   | 2 |
| <i>Installation tools:</i>  |   |
| Self-adhesive cable tie mount.....  | 3 |
| Nylon cable tie 100 mm.....   | 6 |
| <i>Spare parts:</i>   |   |
| Stop spring.....  | 2 |
| <i>Technical documentation:</i>   |   |
| Assembly and operation manual.....  | 1 |
| Certificate.....  | 1 |
| Package.....  | 1 |

### 5. OPTIONAL EQUIPMENT SUPPLIED ON REQUEST

|  |   |
|--|---|
| Wireless remote control kit (consists of a receiver and 2 transmitters (tags) with operation range up to 40m)..... | 1 |
| Siren (for alerts on unauthorized entry attempts) .....  | 1 |
| Intrusion detector .....   | 1 |

## 6. PRODUCT DESCRIPTION

### 6.1 Main features

- The TB-01 turnstile can be operated autonomously: from the remote control panel or wireless remote control, as well as from an access control system (ACS) via readers.
- The TB-01 turnstile is supplied with safe operating voltage – maximum 14 V.
- The turnstile has low power consumption – maximum 20 W.
- At a power supply switching off the turnstile retains the position for each direction set at the moment of power loss: the open passage direction remains open, the closed passage direction remains closed.
- A resetting mechanism ensures automatic reset of barrier arms to home position after each passage.
- Smooth and quite operation of the resetting mechanism is ensured by a damper.

## TB-01 Electromechanical box tripod turnstile with two built-in readers

- To ensure correct register of passages the resetting mechanism has built-in optic rotation sensors.
- A mechanical release lock built into the TB-01 turnstile housing ensures unlocking of the turnstile with a mechanical release key enabling free rotation of barrier arms in a case of emergency.
- Installed in a line several turnstile housings form a secured passage without installation of extra guide barriers.
- Front covers of the turnstile housing feature mnemonic indicators of proximity card readers installed under the front covers.
- When it is required to have a card capture option on entrance or exit the TB-01 turnstile can be used together with a TBC-01 model featuring a built-in card capture reader; the TB-01 and TBC-01 models have matching design and dimensions.

### 6.2. Design

6.2.1 Design of the TB-01 turnstile is shown in Figure 1. Numbers of the items hereinafter refer to the item numbers as shown in Figure 1 unless stated otherwise.

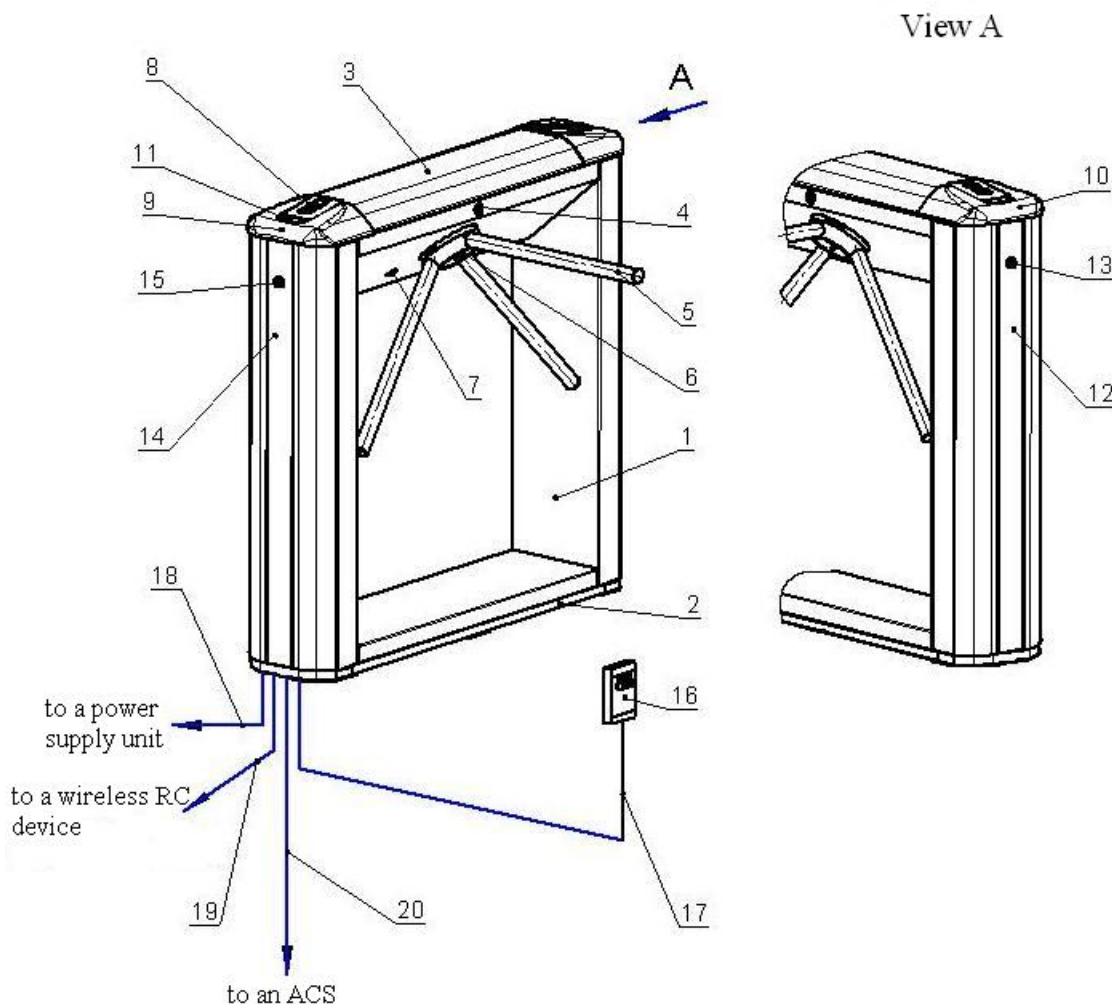

Figure 1 – TB-01 overall view

– *Standard delivery set:*

1 – frame; 2 – base; 3 – top cover; items 1-3 form turnstile housing; 4 – top cover lock; 5 – barrier arm; 6 – cover; 7 – mechanical release lock; 8 – indication module; 9, 10 – front covers with card readers; 11 - blank cover; 12, 14 – turnstile housing side cover; 13, 15 – turnstile housing side cover lock; 16 – RC panel; 17 – RC panel cable;

– *Not included in the standard delivery set:*

18 – power cable; 19 – wireless remote control device cable; 20 – ACS connection cable.

The TB-01 turnstile consists of a turnstile housing with built-in electronics and two card readers, three barrier arms and an RC panel (Ref. Fig. 1, items 1-3, 5 and 16).

The turnstile housing is fixed to floor with 4 anchor bolts through holes in the turnstile housing base (2). The overall dimensions of the TB-01 turnstile housing are shown in Figure 2.

The turnstile housing contains: rotation unit, which includes a resetting mechanism (a pusher, stop springs and a roller), control mechanism with optic sensors and a locking device, as well as a mechanical release lock (7). Rotation unit houses rotation mechanism which includes a damper, a rotation sensor disc and a hub; the point of attachment of the barrier arms to the rotating mechanism is hidden with a cover (6). Front side surfaces of the turnstile housing have side covers (12, 14) with locks (13, 15).

Internal elements of the turnstile housing are accessed through a removable top cover (3); at normal operation of the TB-01 turnstile the top cover lock (4) is locked.

6.2.2 To inform on a current status of the TB-01 turnstile both front sides of the turnstile housing feature indication modules (8), with card readers built-in under, on the internal side of the cover. The indication module has 3 mnemonic indicators:

- Green indicator of authorized passage;
- Yellow indicator: card presentation is expected;
- Red indicator of ban on passage.

6.2.3 Inside the turnstile housing there is a bracket with a CLB mounted on it with terminal clamps for connection of external devices. RC panel, ACS outputs, wireless remote control device (when used), intrusion detector (optional) and emergency unblocking device are connected to the CLB. Connection lines of a power supply unit and signal lines of card readers are connected to the terminal clamps for connection of external devices. External devices are connected in accordance with connection layout (Ref. Fig. A.1 Appendix A). Layout of electrical connections inside the turnstile housing is shown in Figure A.2 Appendix A. The CLB is shown in Figure 3.

6.2.4 The remote control panel is designed as a small desktop device with a shock-proof ABS plastic case and is intended for setting and indicating operating modes when the turnstile is operated manually. The RC panel is connected to the CLB with a flexible multicore cable (17) via a "XT1.L" connector block (Ref. Fig. 3).

The front of the remote control panel houses three control buttons with LED indicators above to set passage modes of the TB-01 turnstile. The "STOP" button in the middle serves for setting the "Always locked" operating mode, the right and left buttons – for unlocking the turnstile in a chosen direction.

The RC panel orientation towards the turnstile (if an operator's terminal is placed at the backside of the turnstile housing) can be changed by swopping wires of the RC panel connected to the contacts: Unlock A and Unlock B respectively, as well as Led A and Led B respectively (Ref. Fig. 3 and A.1 Appendix A).

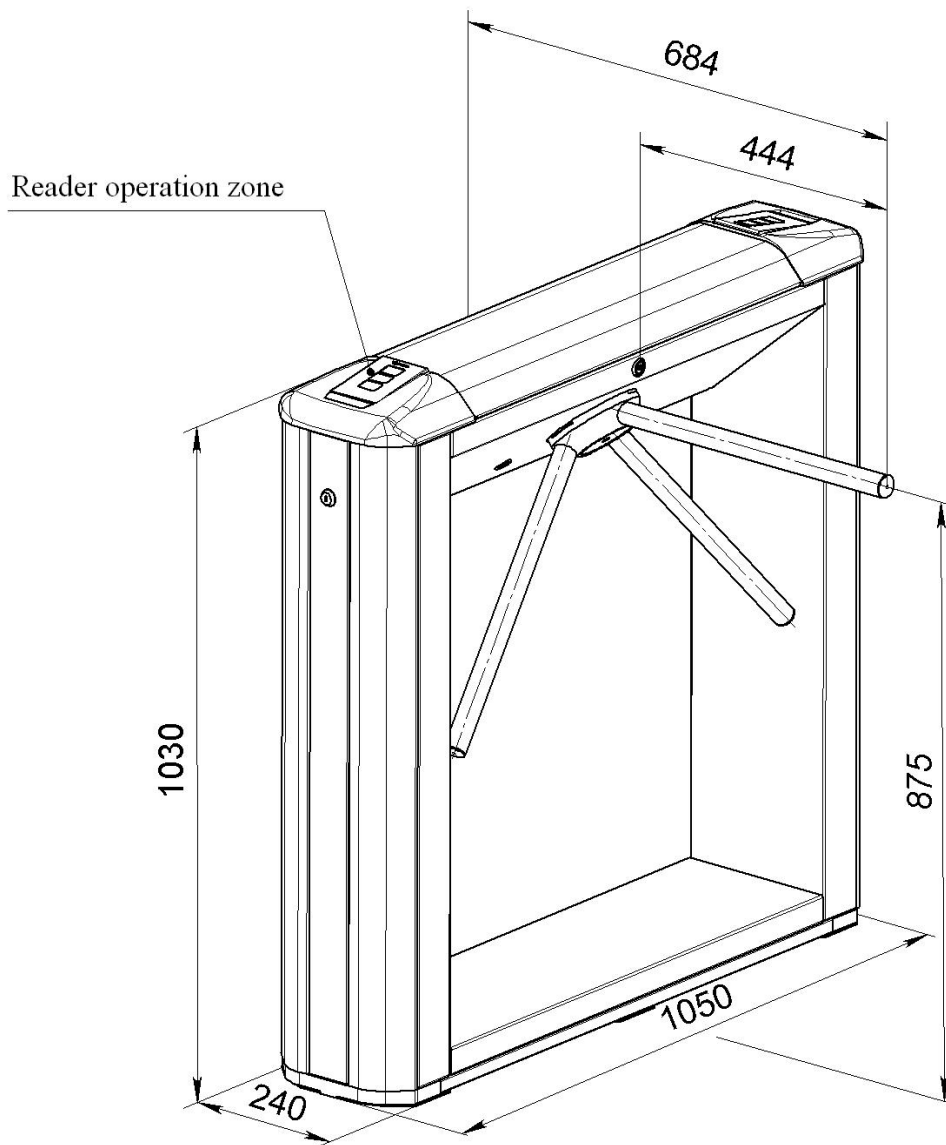

**Figure 2 – Overall dimensions of the TB-01 turnstile**

**6.2.5 The CLB (Ref. Fig. 3) houses:**

- “X1” (Control) connector to connect the control mechanism (connected to the “X1” connector of the control mechanism with the turnstile cable);
- “XT1.L” (In) connector block to connect the RC panel /the wireless remote control/ACS controller inputs as well as an emergency unblocking device;
- “XT1.H” (Out) connector block to connect a siren and outputs, providing the turnstile status data to the ACS controller;
- “XT2” connector block (Detector) to connect an intrusion detector;
- “XT3” (+12VDC) connector block to connect the turnstile power supply;
- “XT4” (Light A) and “XT5” (Light B) connector blocks (at delivery indication of top cover card readers is connected to the connector blocks);
- J1 connector to select the turnstile control mode;
- J2 connector for programming.

**6.2.6** The TB-01 turnstile is powered via a power cable (18). As power supply it is recommended to use 12 VDC power supply with linear stabilization of voltage and pulsation amplitude at output not exceeding 50 mV. Value of output current should be minimum 1,5A.

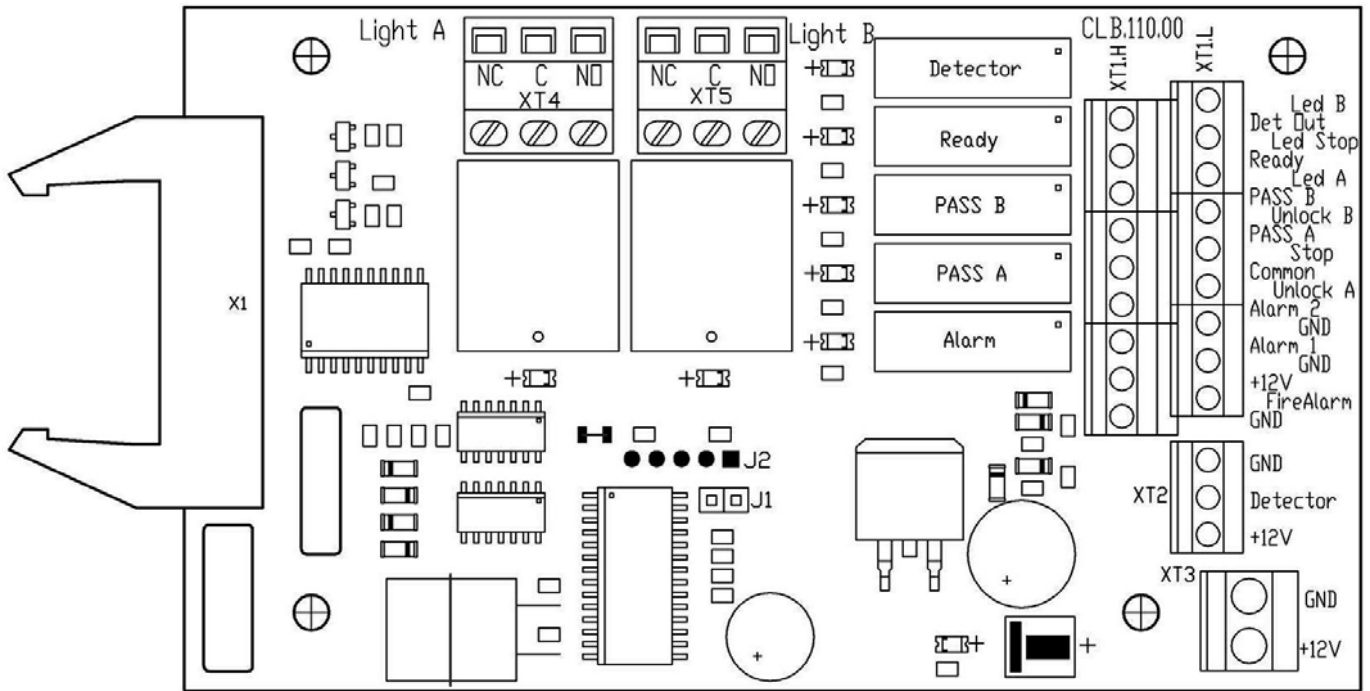

Figure 3 – The CLB

### 6.3. Control over the TB-01 turnstile

6.3.1 The turnstile can be operated from the following control devices:

- RC panel;
- Wireless remote control;
- ACS controller.

The above devices can be connected to the turnstile as follows:

- any device alone;
- in any combination with each other;
- all devices simultaneously (in parallel).

**Note.** At parallel connection of the above devices to the turnstile the superposition of the control signals from them may occur. In that case the turnstile response will conform to response to the obtained combination of input signals. (Appendices B and C).

6.3.2 Connection of the devices mentioned in Clause 6.3.1 is made with cables (17, 19, 20) to the corresponding connector blocks “XT1.L” and “XT1.H” of the CLB in accordance with the connection layout (Ref. Fig. A.1 Appendix A).

6.3.3 The RC panel is connected to the contacts “GND”, “Unlock A”, “Stop”, “Unlock B”, “Led A”, “Led Stop” and “Led B” of the “XT1.L” connector block.

6.3.4 The wireless remote control is connected to the contacts “GND”, “Unlock A”, “Stop” and “Unlock B” of the “XT1.L” connector block. Power supply of the wireless remote control is connected to the contact “+12V” of the “XT1.H” connector block.

6.3.5 The ACS controller outputs are connected to the contacts “GND”, “Unlock A”, “Stop” and “Unlock B” of the “XT1.L” connector block.

6.3.6 The ACS controller inputs are connected to the contacts “Common”, “PASS A”, “PASS B”, “Ready” and “Det Out” of the “XT1.H” connector block.

6.3.7 Pin assignment of the CLB connector blocks are given in Figure 3 and on a label located on the inner surface of the turnstile top cover.

#### **6.4. Input control signals and their parameters at autonomous control**

6.4.1 The CLB microcontroller processes incoming commands (i.e. traces the status of the contacts “Unlock A”, “Stop”, “Unlock B” and “Fire Alarm”), keeps track of the signals from optic sensors and from the intrusion detector (contact “Detector”), and based on those signals, generates commands to the control mechanism and to the external devices – indication on the RC panel (“Led A”, “Led Stop” and “Led B”), the signal of hub turning in the corresponding direction (“PASS A” and “PASS B”), the signal of the turnstile ready for a next command (“Ready”), the alarm output signal (“Alarm”) – and relays the signal of the current status of the intrusion detector (“Det Out”).

6.4.2 The turnstile is operated by input of a low-level signal, relatively to the “GND” contact, to “Unlock A”, “Unlock B” and “Stop” contacts of the “XT1.L” connector block. As a control element there can be used a normally open relay contact or a circuit with open collector output at that. Emergency unblocking of the turnstile is carried out by removing of a low-level relatively to the “GND” contact signal from the “Fire Alarm” contact. As a control element there can be used a normally closed relay contact or a circuit with open collector output at that (Ref. Fig. 4).

**Note:** For generating of a high-level signal at all input contacts (“Unlock A”, “Stop”, “Unlock B”, “Fire Alarm” and “Detector”) 2kOhm resistors connected to the power supply bus “+ 5V” are used.

The control element must provide the following signal characteristics:

the relay contact as the control element:

- minimum switched current.....no more than 2mA;
- closed contact resistance  
(with resistance of the connection cable)..... no more than 300 Ohm;

the circuit with open-collector output as the control element:

- voltage at the closed contact  
(low - level signal at the CLB input) .....no more than 0.8V.

a)

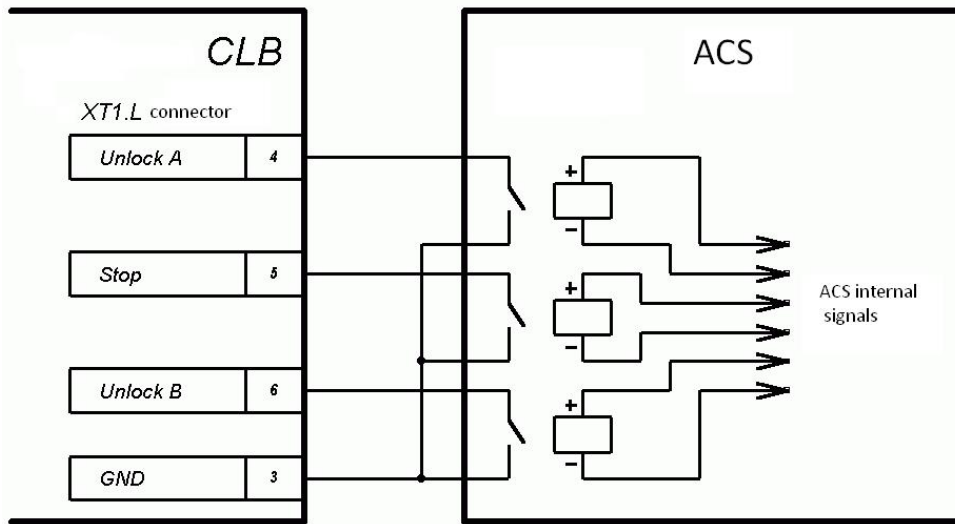

b)

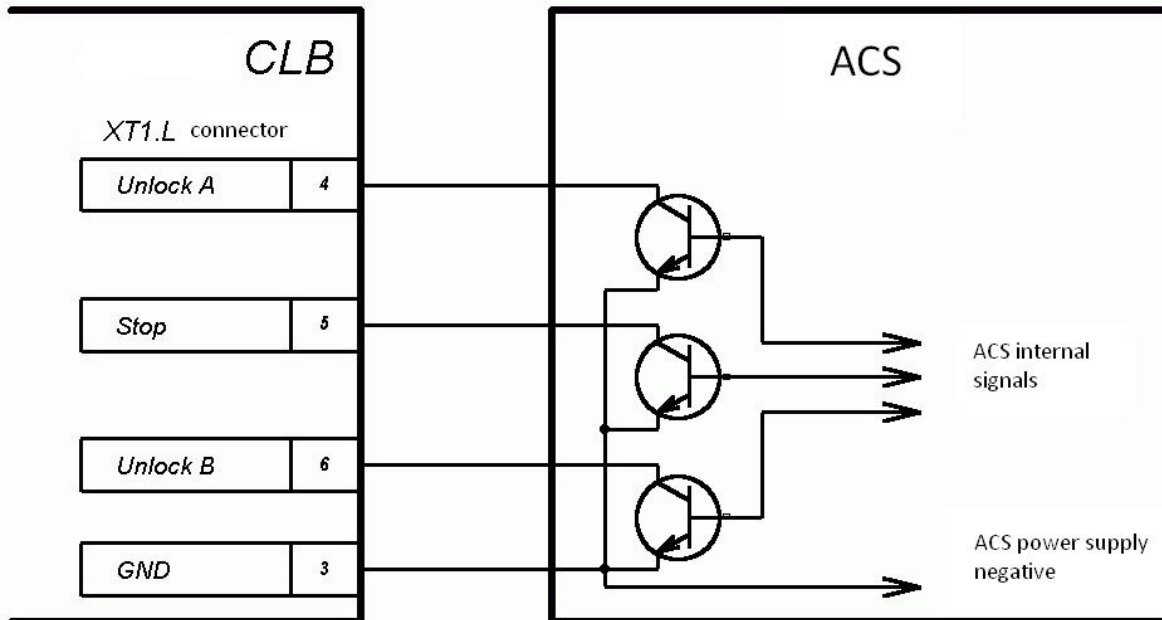

**Figure 4 – Control elements of an external device:**

a – a normally open relay contact;  
 b – a circuit with open-collector output.

6.4.3 The relays “PASS A” (contacts “PASS A” and “Common”), “PASS B” (contacts “PASS B” and “Common”), “Ready” (contacts “Ready” and “Common”), “Detector” (contacts “Det Out” and “Common”) and “Alarm” (contacts “Alarm 1” and “Alarm 2”) have normally open contacts. The “Common” contact, common contact for the relays, at that, is not connected to the negative terminal of the turnstile power supply. In the initial (inactive) state, when the power is on, the relay contacts “PASS A”, “PASS B”, “Ready” and “Detector” are closed (voltage is supplied to the relay coil) and the “Alarm” relay contacts are open (voltage is not supplied to the relay coil). Opening/closing of PASS A, PASS B, Ready,

## TB-01 Electromechanical box tripod turnstile with two built-in readers

Detector and Alarm relays is indicated by lighting/going out of red indicators located near the corresponding relays (Fig. 3). The output cascades for “PASS A”, “PASS B”, “Ready”, “Det Out” and “Alarm” are the relay contacts with the following signal characteristics (Ref. Fig. 5):

- maximum commutation voltage .....42V DC;
- maximum switched current .....0.25A;
- closed contact resistance ..... no more than 0.15Ohm.

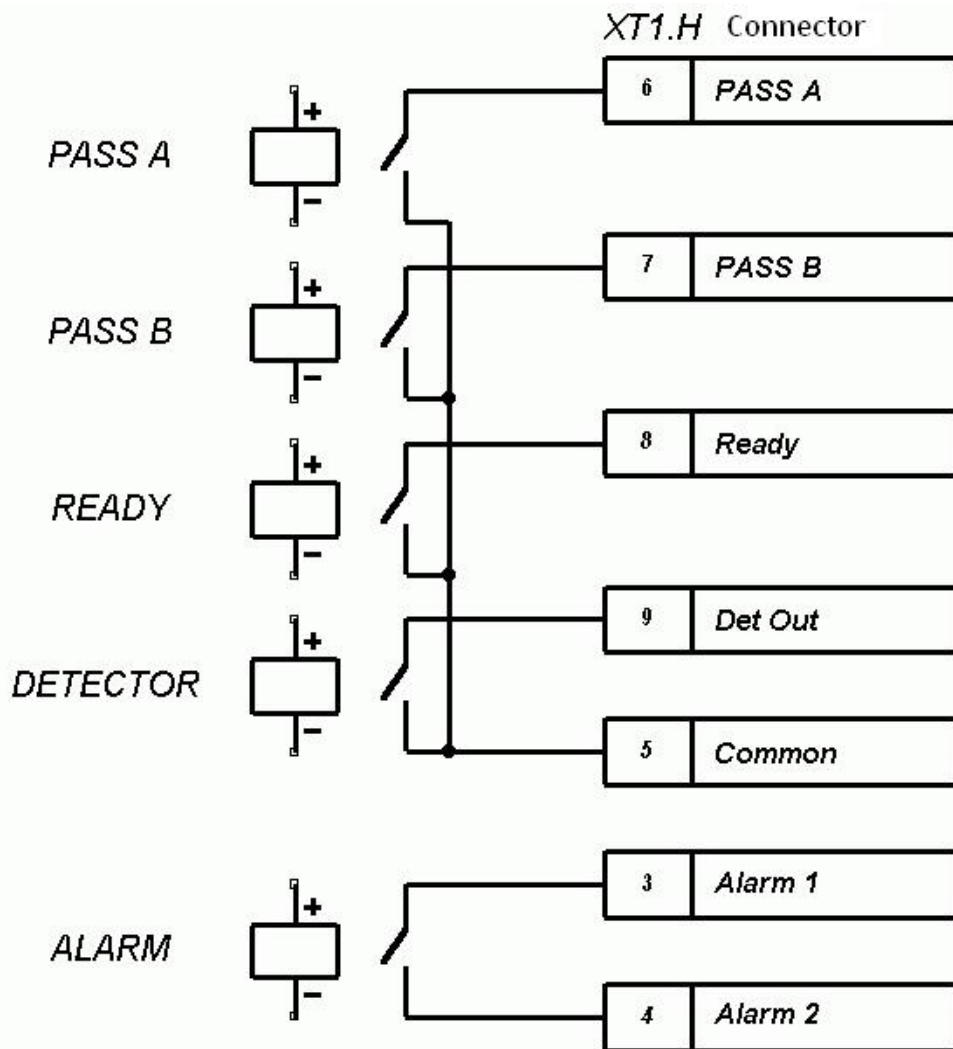

Figure 5 – Output cascades for PASS A, PASS B, Ready, Det Out and Alarm

### 6.5. Control modes

- 6.5.1 There are two modes of the turnstile control - a pulse control mode and a potential control mode. They determine available operating modes of the turnstile (Table 3 and Table 4).
- 6.5.2 The control mode is set by the jumper on a J1 connector (the J1 connector location is shown in Figure 3: the jumper is installed – the pulse control mode, the jumper is not installed – the potential control mode). The jumper is installed at delivery.
- 6.5.3 At both control modes the turnstile is controlled by input of a control signal. Passage waiting time in the pulse control mode is 5 seconds regardless of duration of the control signal (impulse). In the potential control mode passage waiting time equals duration of the control signal.

6.5.4 The pulse control mode is intended for the turnstile operation from the RC panel, wireless remote control or an ACS controller, outputs of which support pulse control mode

Standard control inputs: “Unlock A”, “Unlock B” and “Stop”.

Special control input: “Fire Alarm”.

Refer to Table 3 for the turnstile operating modes at this control mode.

The algorithm of control signals at this mode is described in Appendix B.

To change operating mode of the turnstile the minimum input signal duration should be 100msec. The passage waiting time is 5 sec. and it does not depend on the input signal duration.

Refer to Clause 6.9.3.1 for the turnstile operation at special “Fire Alarm” control input.

6.5.5 The potential control mode is intended for the turnstile operation from an ACS controller, outputs of which support potential control mode (for instance lock controller).

Standard control inputs: “Unlock A” and “Unlock B”

Special control inputs: “Stop” and “Fire Alarm”.

See Table 4 for the turnstile operating modes at this control mode.

The algorithm of control signals at this mode is described in Appendix C.

To change operating mode of the turnstile the minimum input signal duration should be 100msec. The passage waiting time is equal to the low-level signal duration (the turnstile remains open in the set direction if a low-level signal already exists at the set direction input at the moment of passage).

At the low-level signal inputting to the “Stop” input, both directions will lock for the time of the signal duration regardless of the signal strength at the inputs “Unlock A” and “Unlock B”. At the removing of a low-level signal from the “Stop” input, the directions will set to the modes according to the signal strength at the inputs “Unlock A” and “Unlock B”.

See Clause 6.9.3.2 for the turnstile operation at the special “Fire Alarm” control input.

## 6.6. Operation from the RC panel

6.5.1 When the buttons on the RC panel are pressed (the STOP button and the two buttons corresponding to a passage direction), the closing of the relevant contact “Stop”, “Unlock A” or “Unlock B” to the contact “GND” occurs (i.e. forming of the low-level signal relatively to the contact “GND”).

6.5.2 Operation logic of the turnstile at the single passage in the A(B) direction at the pulse control mode:

6.5.2.1 When the button, corresponding to the A (B) passage direction, is pressed on the RC panel, the closing of the contact “Unlock A(B)” to the contact “GND” occurs (i.e. forming of the low-level signal on the contact “Unlock A(B)” relatively to the contact “GND”).

6.5.2.2 The CLB microcontroller processes an incoming command and generates a command to the control mechanism, which opens the A (B) passage direction (lifts the upper (lower) edge of the key holt).

6.5.2.3 The microcontroller traces a status of the optic sensors, which become active/normal in a certain sequence at barrier arm rotation,

## **TB-01 Electromechanical box tripod turnstile with two built-in readers**

- and counts the time passed since the moment the RC button corresponding to the permitted passage direction A (B) is pressed.
- 6.5.2.4 At the barrier arms turning 67° the microcontroller forms signal “PASS A (B)” (breaking of the contacts “PASS A (B)” and “Common” occurs).
- 6.5.2.5 After the barrier arms turning 67° or after 5 seconds since the moment of pushing the RC button corresponding to the permitted passage direction A (B), the microcontroller generates a command to the control mechanism, which closes the passage direction A (B) (drops the upper (lower) edge of the key hole).
- 6.5.2.6 When the barrier arms reset to home position (barrier arms turning 112°), the microcontroller removes the signal “PASS A (B)” (contacting of the “PASS A (B)” and “Common” takes place).
- 6.5.3 The “Always free” operating mode particularity: in this mode the command described in Clause 6.6.2.5 is not generated and the set passage direction remains open.

### **6.7. Operation from wireless remote control**

- 6.5.1 Control over the turnstile with the wireless remote control is similar to that with the remote control panel.
- 6.5.2 The buttons on the wireless remote control tag act the same way as those on the RC panel.
- 6.5.3 The wireless remote control operation manual is supplied with that device.

### **6.8. Operation from an ACS controller**

- 6.5.1 In the pulse control mode control over the turnstile from an ACS controller is similar to that one with the RC panel.
- 6.5.2 In the potential control mode control over the turnstile from an ACS controller is similar to that one with the RC panel and lies in forming of a low-level signal on the contacts “Unlock A”, “Stop” and “Unlock B” relatively to the contact “GND”.
- 6.5.3 The difference of the operation logic in the potential control mode compared to the one in the pulse control mode (as per Clause 6.6.2): the command described in Clause 6.6.2.5 is generated only at the moment the RC button corresponding to the passage direction A(B) is released. Therefore to arrange single passages in the potential control mode it is recommended to remove the control low-level signal at the beginning of the “PASS” signal of the corresponding direction.
- 6.5.4 The passage through the turnstile in the A (B) direction gets registered based on the status of the output contacts “PASS A(B)” and “Common”.

### **6.9. Optional external devices connected to the turnstile**

- 6.9.1 The following external devices can be connected to the turnstile:
- an intrusion detector and a siren;
  - an emergency unblocking device;
- 6.9.2 The intrusion detector is connected to the “XT2” connector block, and the siren is connected to the “XT1.H” connector block of the CLB according to the connection layout (Fig. A.1 Appendix A and Fig. 3). The intrusion detector should have normally closed contacts.

**Note! Only the manufacturer should carry out installation of an intrusion detector on a turnstile housing.**

If while the turnstile is in a locked state (in the “Always locked” mode or in the “Both directions locked” mode, Tables 3 and 4) a signal from the intrusion detector comes, the “Alarm” signal is generated, which is disabled either after 5 sec. or after execution of any received command. The signal from the intrusion detector is ignored for the period of authorized unlocking of the turnstile in either or both directions.

A signal coming from the intrusion detector within 3 sec. after the “Always locked”/“Both directions locked” mode is set, is ignored.

A signal on current status of the intrusion detector is constantly transmitted to the “Det Out” and “Common” contacts of the CLB “XT1.H” connector block (Fig. 3).

6.9.3 The emergency unblocking device is connected to the “XT1.L” connector block of the CLB in accordance with the connection layout (Figure A.1 Appendix A and Figure 3). If the “Fire Alarm” input is not used, it is necessary to install a jumper between the contacts “Fire Alarm” and “GND”. This jumper is installed at delivery.

Operation of the turnstile under commands of the emergency unblocking device:

6.9.3.1 In the pulse control mode, when a low-level signal is removed from the “Fire Alarm” input, both passage directions open for the whole period of the signal absence. Other control commands are ignored at that. When the low-level signal appears at the “Fire Alarm” input, the turnstile turns to the “Always locked” mode.

6.9.3.2 In the potential control mode, when a low-level signal is removed from the “Fire Alarm” input, both passage directions open for the whole period of the signal absence. Other control commands are ignored at that. When the low-level signal appears at the “Fire Alarm” input, the passage directions turn to the mode in accordance with the signal levels at the inputs “Unlock A”, “Unlock B” and “Stop”.

## 6.10. Unblocking with a mechanical release key

Mechanical release function is intended for unlocking barrier arms ensuring free rotation in case of emergency, or at a power supply failure.

To unlock the turnstile with a mechanical release key proceed as follows:

- Insert the key into a mechanical release lock (7);
- Turn the key clockwise till it stops (open the lock, the lock cylinder will move out at this);
- Return the key into its reset position and take it out of the lock;
- Make sure the TB-01 turnstile is unlocked by turning the barrier arms in both direction several times;

To mechanically lock the TB-01 turnstile:

- Install the barrier arms in their home position;
- Press the lock cylinder into lock case till it clicks (without the key);
- Make sure the turnstile is locked and the barrier arms cannot be free rotated manually.

## 6.11. Operation contingencies and response

6.11.1 The turnstile is capable of providing information on the following operation contingencies:

- unauthorized access;
- passage delay for more than 30 sec.;
- one or both optic sensors are out of order.

A special signal “Ready” is generated in each of the above cases.

- 6.11.2 In case of unauthorized access the “Ready” signal is formed as follows: at 8° arm rotation one of the optic sensors (Fig. 10) responds and the output contacts “Ready” and “Common” get broken (the beginning of the signal). When the barrier arms reset to home position, the both optical sensors become normal and the output contacts “Ready” and “Common” get closed (the finish of the signal).
- 6.11.3 In case of delay of an authorized passage for more than 30 sec. the signal “Ready” is formed as follows: if within 30 seconds from the moment of passage commencing, which is determined by the arm rotation at no less than 8° (i.e. activation of one of the optic sensors), the reset of barrier arms to home position does not happen, the output contacts “Ready” and “Common” break (the beginning of the signal). When the barrier arms reset to home position, the both optic sensors become normal and the output contacts “Ready” and “Common” get closed (finish of the signal).
- 6.11.4 When one or both of the optic sensors become out of order, the output contacts “Ready” and “Common” get broken (the beginning of the signal “Ready”). After fault removal the closed status of the contacts “Ready” and “Common” is resumed.

## **7. MARKING AND PACKAGING**

- 7.1 The turnstile has a marking sticker on the internal side of the turnstile top cover and a label – inside, on the rear side of the turnstile housing. To get access to the marking sticker and the label, open the top cover (3).

To do so proceed as follows:

- Switch off power supply of the turnstile;
- Insert the key into the top cover lock (4);
- Turn the key clockwise till it stops (open the lock, the lock cylinder will move out together with a lock bolt at this);
- Holding the front edge of the top cover (3) carefully lift it and turning it remove it from the turnstile housing. Be careful not to damage the CLB located under the cover while removing the top cover;
- Place the top cover on a flat steady surface.

Installation of the top cover back into its operation position is carried out in reverse order. After mounting the top cover, lock the top cover lock by pushing lock cylinder into its case till it clicks. Turn on the TB-01 turnstile power supply.

- 7.2 To protect the turnstile against damage during transportation and storage the TB-01 turnstile as standard (Ref. Section 4) is packed in a transportation box, 1200x390x1100 mm, weight brutto– 88 kg.

## **8. SAFETY REQUIREMENTS**

### **8.1. Installation safety requirements**

- 8.1.1 The installation should be carried out only by qualified personnel after careful study of this Manual with observance of general safety rules.
- 8.1.2 Only serviceable tools should be used for installation.
- 8.1.3 All works should be performed only after the power supply is switched off and disconnected from the AC mains.
- 8.1.4 During installation before the turnstile housing is fixed to the floor be care-

ful not to drop the turnstile housing.

8.1.5 Before first power-up of the TB-01 turnstile make sure installation and all connections are done properly.

8.1.6 Installation of a power supply unit must be performed with observance of safety requirements mentioned in its certificate.

### 8.2. Operation safety requirements

8.2.1 Observe general electrical safety rules when operating the turnstile.

8.2.2 Do not use the turnstile under conditions that do not comply with the requirements of Section 2 of this Manual.

8.2.3 Do not use the turnstile at supply voltage that does not comply with the requirements of Section 3 of the Manual.

8.2.4 Power supply unit must be operated with observance of safety requirements mentioned in its certificate.

## 9. INSTALLATION INSTRUCTIONS

### 9.1. Installation details

It is recommended:

- to mount the turnstile on steady and level concrete (grade 400 or higher, strength class B22,5), stone or similar foundations at least 150mm thick;
- to level the foundation so that the anchoring points of the turnstile lie in the same plane (check it with a level);
- to apply reinforcing elements (550x550x200mm) for installation on less steady foundation;
- to mark the mounting holes according to Figure 7;
- to control vertical alignment of the turnstile with a level during installation;
- to do installation of the TB-01 turnstile by at least 2 skilled installers;
- when arranging a passage area through the turnstile please take into account that the resetting mechanism operates as follows:
  - at the barrier arm turning at the angle of more than 60 the reset is effected in the direction of movement;
  - at the barrier arm turning at the angle less than 60 the reset is effected counter the movement direction (reset to home position).

**Note:** The angle gradient, at which the barrier arm reset commences, may vary in the range of  $\pm 5^\circ$ .

To ensure accurate passage tracking, when the turnstile is operated from an ACS, it is recommended to arrange the passage area in such a way that the barrier arms should turn in the direction of movement at the angle no less than  $70^\circ$  (Fig. 6).

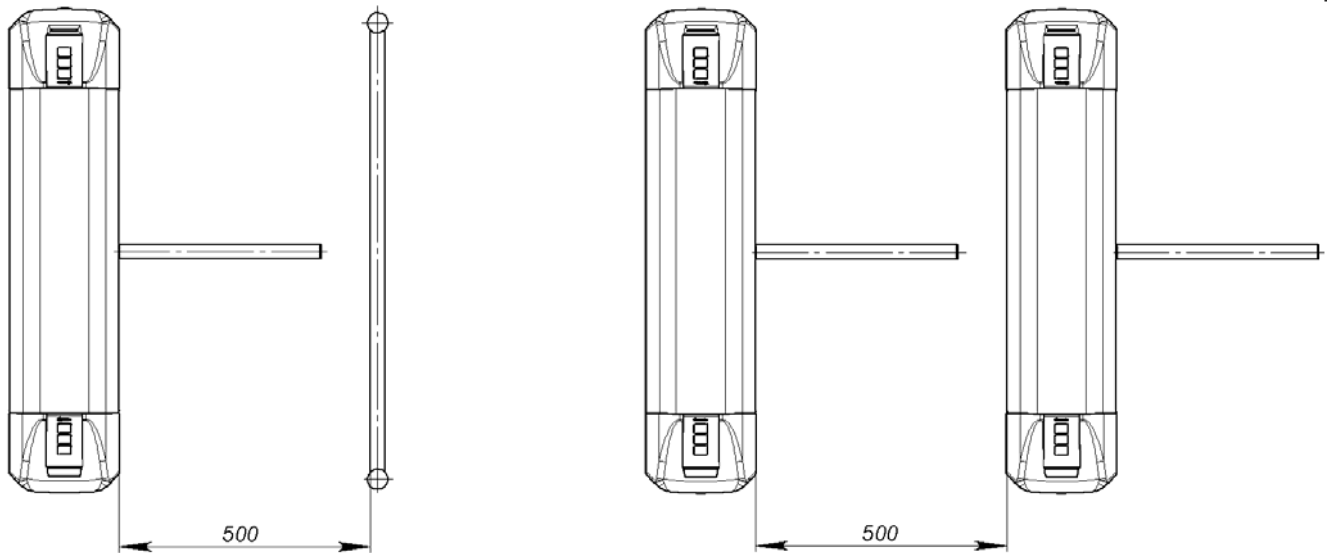

**Figure 6 – Installation recommendations**

## 9.2. Installation tools

- hammer drill 1,2÷1,5 kW;
- hard-alloyed drill bit  $\varnothing 16$  mm for anchor bolt sleeves;
- floor chaser for cable raceways;
- flat slot screwdriver №2;
- flat slot screwdriver №5 (length 150 mm);
- cross-head screwdriver №2;
- horn-type and socket wrenches: S17, S13, S10, S8, S7;
- level;
- measuring tape 2 m;
- slide caliper.

Note: It is allowed to use other testing equipment and measuring tools provided the equipment in use ensures the required parameters and measurement accuracy.

## 9.3. Cable length

The maximum allowed length of the remote control panel / wireless remote control cable is 30m.

The maximum allowed length of the turnstile power cable depends on the cable cross-section and should not exceed:

- for cable with 0.75mm<sup>2</sup> cross – section (AWG 18) ..... 10 m;
- for cable with 1.5mm<sup>2</sup> cross – section (AWG 16) ..... 30 m.

## 9.4. Installation procedure

Note! The manufacturer shall not be liable for any damage caused as the result of improper installation and declines any claims arising thereof in case if the installation is done not in compliance with the instructions provided in this Manual.

9.4.1 Unpack the TB-01 turnstile and check the completeness as per Section 3 of the product certificate.

9.4.2 Make holes for anchor bolt sleeves for the turnstile housing installation (Fig. 7).

Prepare a cable raceway for cables when cables are laid concealed under floor. Install and fix the turnstile housing only after all cables inside the turnstile housing and in

electric raceways are laid. Cable routing inside the turnstile housing is shown in Figure 8.

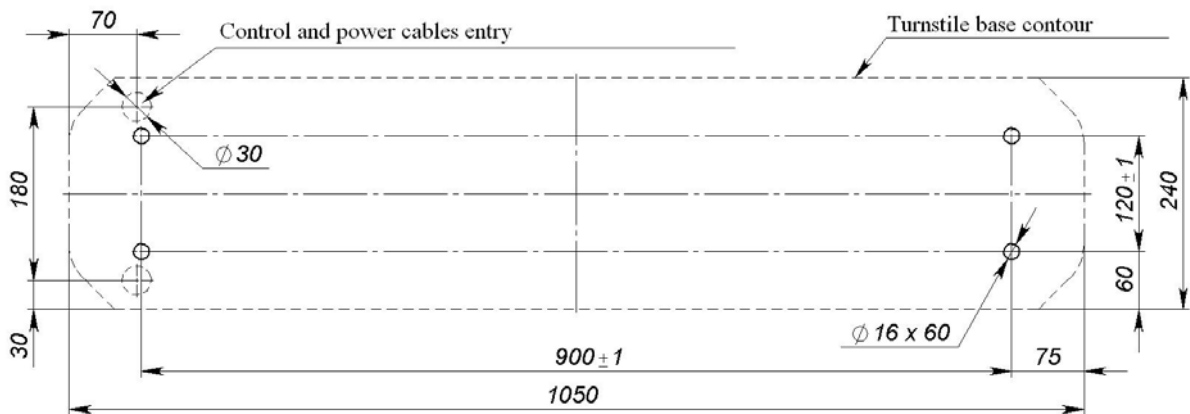
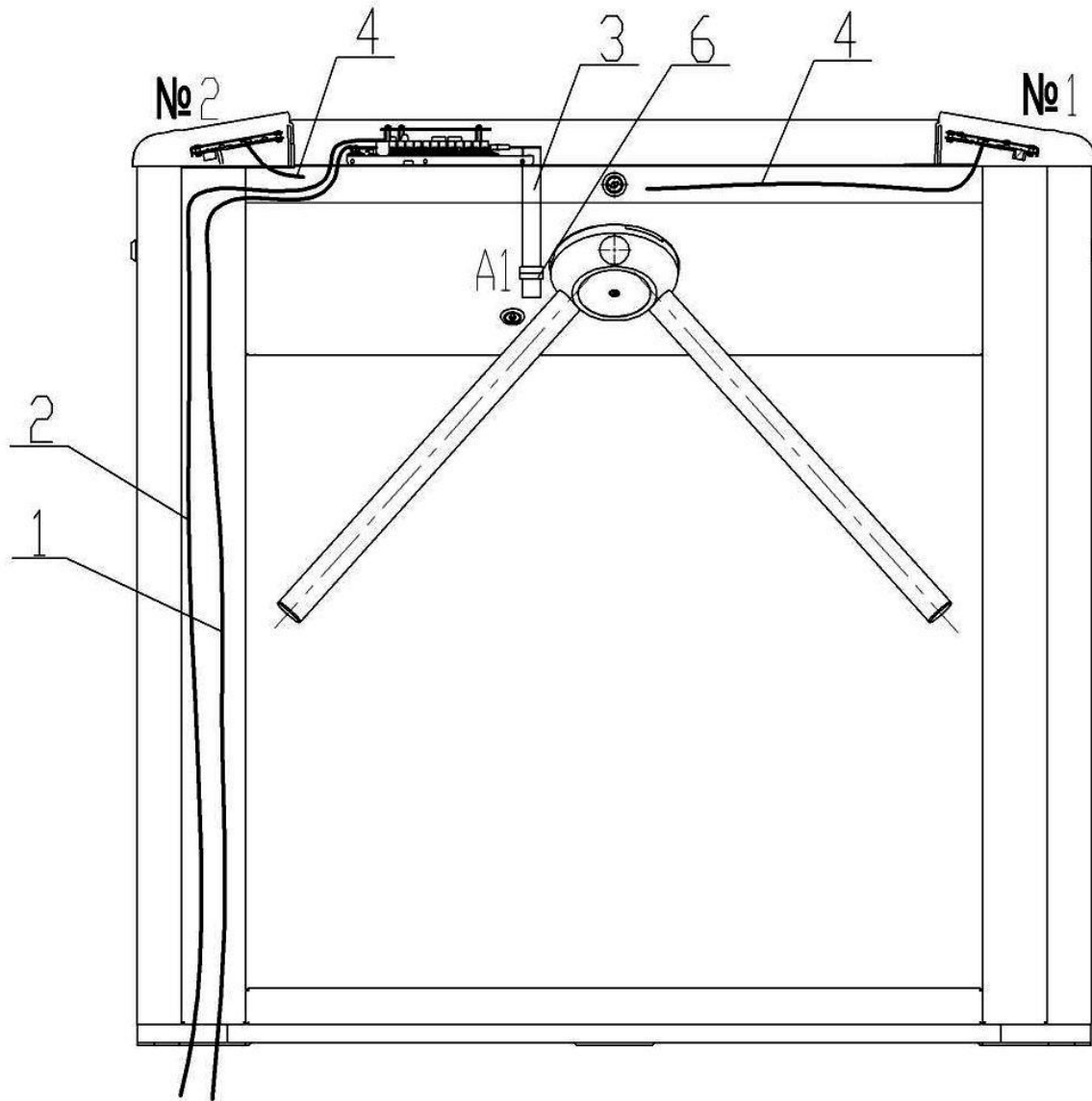

**Figure 7 – TB-01 turnstile housing installation layout**

- 9.4.3 Insert anchor bolts sleeves into the holes so that they did not stick out above the floor surface. Remove the turnstile housing side covers (12, 14) by unlocking the locks (13, 15). Set up the housing on anchor bolt sleeves and fix it with the M10 bolts.
- 9.4.4 Install the turnstile power supply unit in its place (See power supply unit certificate for installation procedure of the power supply unit).
- 9.4.5 Remove the turnstile housing top cover (3) by unlocking the lock with a key (4 ref. Section 6).
- 9.4.6 Connect the power cable (18) to a connector block “X1.1” (Ref. Fig. A.1 Appendix A). Connect the cable (17) of the RC panel (16) to a connector block “XT1.L” on the CLB (Fig. 3). Connect cables of other devices, when used, to corresponding connector blocks of the CLB (Ref. Fig. 3 and Fig. A.1 Appendix A).
- 9.4.7 Check serviceability and accuracy of all the electrical connections. Fix the cables using self-adhesive cable tie mounts and nylon cable ties supplied with a standard delivery set. After all cables are connected and the turnstile housing is fixed to the floor return the top cover (3) to its place (Ref. Section 6) and the turnstile housing side covers (12, 14) in order reverse to their removing.
- 9.4.8 To mount the barrier arms into the run position remove the cover (6) from the hub after unscrewing the screw M4x25. Unscrew the M8x30 bolt on the barrier arm (5). Fit the barrier arm into the mounting hole on the hub and fasten it with the bolt. Put a spring washer under the bolt head. The bolts must be tightened so as to ensure reliable non-play fixation of the barrier arms.

Repeat the above-described procedure for fitting up the remaining barrier arms. Put the cover (6) in its operation position and fix it with the screw.

- 9.4.9 Run a test switch on of the turnstile as specified in Clause 10.2. After the installation and testing are complete the turnstile is ready to operate.



Top view without covers

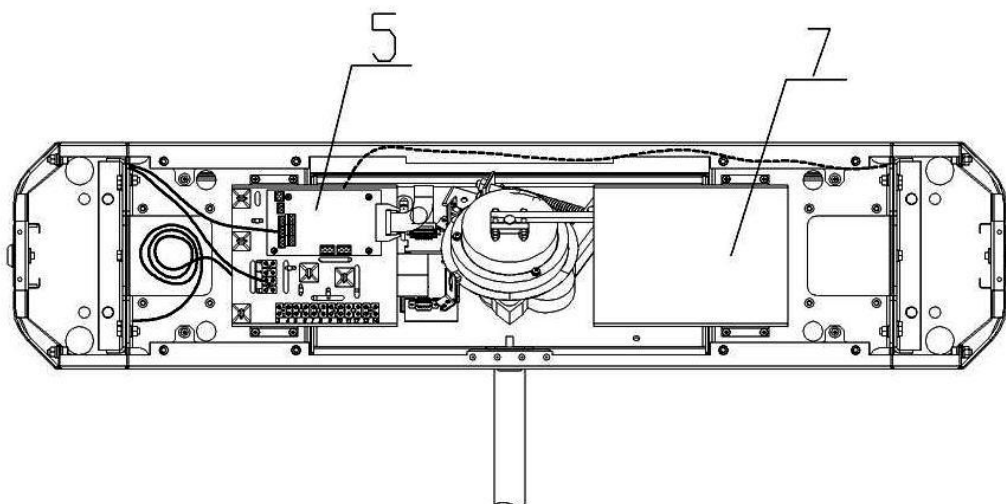

Figure 8 – Cable routing inside the TB-01 turnstile housing:

- 1 – power cable; 2 – cable from the RC panel/ wireless remote control device; 3 – rotation mechanism connection cable; 4 – cables of card readers №1 and №2; 5 –CLB; 6 – rotation mechanism; 7 - bracket (ACS installation)  
 №1 – cover with reader 1; №2 – cover with reader 2.

**9.5. Connecting readers to an ACS**

The readers are connected to an ACS controller with a shielded cable in accordance with Figure A.1 Appendix A.

The readers' lines are connected to the connector blocks X1.2 (Ref. Fig. A.1 Appendix A).

Reader №1 lines are connected to clamps:

- 3 (data line D0),
- 4 (data line D1),
- 7 (sound signal line),
- 8 (common cable and shield line) in accordance with Figure A.1 Appendix A.

Reader №2 lines are connected to clamps:

- 9 (data line D0),
- 10 (data line D1),
- 13 (sound signal line),
- 14 (common cable and shield line) in accordance with Figure A.1 Appendix A.

When the readers are connected to an ACS as per aforementioned scheme format of outgoing data is Wiegand 26 (orange wire – WF is not connected anywhere). Format of outgoing data Wiegand 26 is ensured regardless of a format of used identifiers.

LED indication of the readers is connected to outputs of the CLB at the factory, this ensures proper operation of the turnstile indication.

For external control over indication from an ACS disconnect from connectors XT4, XT5 of the CLB blue and yellow wires of the readers and connect them to a connector block X1.2 in accordance with color marking: for reader № 1 blue wire to a clamp 5, yellow wire to a clamp 6; for reader № 2 blue wire to a clamp 12, yellow wire to c clamp 11.

LED indication of a reader is controlled as follows:

Table 1.

| Control signals at a connection cable of a reader |             | LED light in different modes at external control |
|---|-------------|--|
| Blue wire   | Yellow wire |  |
| 0   | 0           | Red and green                                    |
| 0   | HZ          | red  |
| HZ  | 0           | green  |
| HZ  | HZ          | yellow   |

- 0 – control line is connected with a negative terminal of a power supply unit;
- HZ – high resistance at a control line (the line is not connected with a negative terminal of the power supply unit).

For external initiation of a sound announcer of a reader its brown wire is connected to a negative terminal of a power supply unit.

All changes are done before power supply is applied to a reader.

When the cable between a reader and an ACS controller is extended it is recommended to arrange switching over of external control over LED indication and format of outgoing data in the connection place of a regular reader cable with an extension cable.

To change a format of outgoing data of Wiegand interface an orange wire is used (WF – Wiegand-Format). To change format of outgoing data of Wiegand interface connect the orange wire (WF) in accordance with the table below.

Change of outcoming data format of the readers:

| Wire determining a format of outcoming data | Connection point (conductor) at an output of a regular connection cable of a reader | Format of outcoming data of a reader determined by performed connections |
|---|---|--|
| <b>Wiegand Interface</b>                    |   |  |
| Orange (WF)                                 | D0 (green)  | Wiegand 37   |
| Orange (WF)                                 | “ground” (black + shield)   | Wiegand  |
| Orange (WF)                                 | ~ (not connected)   | Wiegand 26   |

**ATTENTION!** Switching over the reader into one of the abovementioned Wiegand formats does not prevent it from reading cards of other formats and delivering read code to an output of a reader in the set format.

## 10. OPERATION INSTRUCTIONS

### 10.1. General

#### **ATTENTION!**

- **Observe general electrical safety requirements during the turnstile operation.**
- **Do not connect the turnstile power supply to the mains with the voltage and frequency rating other than specified in the Power supply certificate.**
- **Do not use substances for cleaning of the turnstile that may cause mechanical damage or corrosion of the surfaces;**
- **Do not move through the turnstile passage area any objects with dimensions exceeding the width of the passageway;**
- **Do not jerk and hit any elements of the turnstile so as to prevent their mechanical deformation.**
- **Do not dismantle or adjust mechanisms ensuring operation of the turnstile.**

### 10.2. Power-up

**WARNING! Observe general electrical safety requirements during the turnstile operation.**

Check accuracy of all the connections (see Clause 9.4). Make sure the barrier arms are in home position (passage area is blocked with a barrier arm). Ensure mechanical release lock is locked (The TB-01 turnstile is locked. Ref. Clause. 6.10).

Connect the turnstile power supply unit to the AC outlet with the voltage and frequency rating according to the certificate for the power supply unit.

Switch on the turnstile power supply unit. Yellow indicators (card presentation is expected) will light up on the indication modules, on the RC panel the red indicator above “Always locked” will light up.

### 10.3. Turnstile operating modes in pulse control mode

See Table 3 for the operating modes set from the RC panel and for the corresponding indication. Please note the following:

- Setting the operating modes for each direction is independent, i.e. setting the operating mode for one direction does not change the operating mode set earlier for the opposite one;
- The “Single passage in the set direction” mode can be changed to the “Always free” mode for the same direction, or to the “Always locked” mode;
- The “Free passage in the set direction” mode can be changed to the “Always locked” mode only.

At the turnstile power supply switching-on the reset state of the turnstile is “Always locked” (the mechanical release lock (7) is locked at that).

In the “Single passage in the set direction” mode the turnstile will lock automatically after a person’s passage in the set direction. The turnstile will also lock automatically, if the passage is not made within 5 sec. In the “Bi-directional single passage” mode after the passage in one direction the countdown of the passage waiting time (5 sec.) for the opposite direction is resumed.

**Note:** Pressing the button on the RC panel corresponds to the low-level signal supply to the contacts (“Unlock A”, “Unlock B” и “Stop”) of the “XT1.L” connector block relatively to the contact “GND”.

TABLE 3

#### Pulse control mode

| № | THE TURNSTILE OPERATING MODES  | ACTIONS TO DO  | INDICATION ON THE RC PANEL   | LED INDICATION ON THE TURNSTILE HOUSING                | TURNSTILE RESPONSE AFTER BARRIER ARMS TURN                |
|---|--|--|--|--|---|
| 1 | Always locked (Locked for entry and exit)  | Press the STOP button on the RC panel  | The red indicator above the STOP button is on                              | The red indicator STOP is on                           |   |
| 2 | Single passage in the set direction (open for passage of one person in the chosen direction) | Press the button on the RC panel corresponding to the chosen passage direction | The green indicator above the button of the chosen passage direction is on | The “Green arrow”, showing the passage direction is on | The turnstile locks                                       |
| 3 | Bi-directional single passage (open for one passage in each direction)                       | Press both the left and right buttons on the RC panel simultaneously           | The two green indicators (left and right) are on                           | The two “Green arrows” (left and right) are on         | The turnstile locks in the direction of completed passage |

**TB-01 Electromechanical box tripod turnstile with two built-in readers**

|   |  |   |  |   |  |
|---|--|---|--|---|--|
| 4 | Free passage in the set direction (open for free passage in the chosen direction)  | Press the STOP button and the button corresponding to the chosen passage direction simultaneously | The green indicator above the button of the chosen passage direction is on | The "Green arrow" showing the passage direction is on | Turnstile remains open in the set direction  |
| 5 | Free passage in the set direction and single passage in the opposite direction (open for free passage in the chosen direction and for passage of one person in the opposite direction) | Carry out actions stated in Clauses 2 and 4 of the present table in any sequence                  | The two green indicators (left and right) are on                           | The two "Green arrows" (left and right) are on        | After passage in the free passage direction the turnstile remains open in both directions. After passage in the single passage direction the turnstile remains open in the free passage direction but it gets locked in the single passage direction |
| 6 | Always free (open for entry and exit)  | Press all the 3 buttons on the RC panel simultaneously  | The two green indicators (left and right) are on                           | The two "Green arrows" (left and right) are on        | The turnstile remains open   |

**10.4. Operation of the TB-01 turnstile in potential control mode**

Operating modes are set and indicated on the RC panel in accordance with Table 4. Passage directions are independent of each other, i.e. setting passage mode in one direction does not change passage mode set for the other direction.

**Potential control mode**  
(the jumper is taken off the J1 connector)

| № | THE TURNSTILE OPERATING MODES  | LEVELS ON THE CONTACTS TO BE PROVIDED   | INDICATION ON THE RC PANEL   | LED INDICATION ON THE TURNSTILE HOUSING                | TURNSTILE RESPONSE AFTER BARRIER ARMS TURN   |
|---|--|---|--|--|--|
| 1 | Both directions are locked (the turnstile is locked both for entry and exit)                   | The high level – on contacts “Unlock A” and “Unlock B” or low level – on the contact Stop                       | The red indicator above the STOP button is on                              | The red STOP indicator is on                           |  |
| 2 | One of the passage directions is open (the turnstile is open for passage in the set direction) | The low level – on the contact corresponding to the passage direction, the high levels – on the other contacts  | The green indicator above the button of the chosen passage direction is on | The “Green arrow”, showing the passage direction is on | If by the moment of passage through the turnstile the low level is present on the contact, corresponding to the set passage direction, the turnstile remains open in the set direction |
| 3 | Both passage directions are open (the turnstile is open for passage in both directions)        | The low levels – are on the contacts corresponding to the both directions, the high level – on the contact Stop | The two green indicators (left and right) are on                           | The two “Green arrows” (left and right) are on         | If by the moment of passage through the turnstile the low level is present on the contact, corresponding to the set passage direction, the turnstile remains open in the set direction |

**Note:**

**for ACS outputs:**

- 1 High level – contacts of an output relay are open or output transistor is closed;
- 2 Low level – contacts of an output relay are closed or output transistor is open.

**10.5. Operation of the turnstile when controlled by an ACS**

When a registered access card is presented to a reader, the reader produces a short signal and transmits an access card code to a controller. The ACS authorizes the passage and sends a command to the CLB, which opens passage in authorized direction. After the passage completion the CLB generates PASS A and PASS B signals, locks the passage and resets to home position, after this the turnstile is ready for next operation cycle.

**10.6. In case of an emergency**

**10.6.1 Unlocking with a mechanical release key**

This function allows for fast unlocking with a mechanical release key, ensuring free rotation of barrier arms in both directions. Please refer to Clause 6.10 for how to proceed to unlock the turnstile with a mechanical release key.

**10.6.2 Anti-panic folding arms**

To provide an additional emergency exit the TB-01 turnstile can be equipped with anti-panic folding arms. Without any special keys or tools the folding arm option allows you to clear the passageway in emergency situations – just pull it out in its axis direction, until the rotation mechanism is free, and then fold the arm down (Ref. Fig. 9).

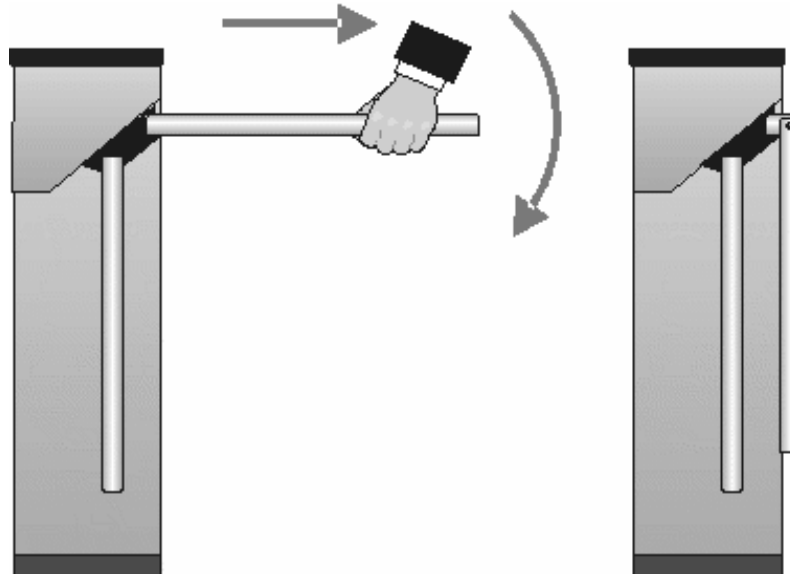

**Figure 9 – Anti-panic folding arms**

**10.7. Possible faults**

Possible faults, which can be cleared by the users themselves, are listed in Table 5.

Table 5

Possible faults and remedy

| FAULT  | POSSIBLE CAUSE  | REMEDY  |
|--|---|---|
| At the power-up the turnstile won't work, no light indication on the turnstile housing and the RC panel                              | No supply voltage to the CLB                                  | Switch off the turnstile power supply from the AC mains, open the turnstile housing top cover. Check the power cable serviceability and reliability of its connection to the CLB "XT3" connector block  |
| The turnstile is not controlled in one of the directions, and there is light indication on the turnstile housing and on the RC panel | The CLB does not receive a control signal from this direction | Switch off the turnstile power supply from the AC mains, open the turnstile housing top cover. Check the remote control panel / wireless remote control kit / ACS controller cable serviceability and reliability of its connection to the CLB "XT1.L" and "XT1.H" connector blocks |

All other faults shall be cleared by the Manufacturer.

**Note:** in case of power supply failure the turnstile retains a status that was set at the moment of power loss for the whole period of power absence.

When the turnstile power supply is restored the turnstile switches to an operating mode depending on signals at control inputs as per the aforementioned operating modes (Table 3, Table 4).

### 11. TRANSPORTATION AND STORAGE

- 11.1 The turnstile in the original package should be transported in closed freight containers or other closed type cargo transport units.
- 11.2 During storage and transportation the boxes with the turnstiles can be stacked maximum 2 layers high.
- 11.3 Storage of the turnstile is allowed in dry indoor facilities at an ambient air temperature from -40°C to + 45°C at relative air humidity 80% at 15°C.
- 11.4 After transportation or storage at temperatures below zero or at high air humidity, prior to installation the turnstile must be kept in the original package for no less than 24 hours indoors under conditions corresponding to operation conditions (Ref. Section 2).

### 12. MAINTENANCE

The turnstile maintenance is required once a year and in case of any technical failures the turnstile must be serviced immediately after repair works. The maintenance should be carried out by qualified mechanic only after careful study of this Manual.

12.1 To do maintenance proceed as follows:

- Disconnect the turnstile power supply from the AC mains;
- Remove the turnstile top cover (3) from the turnstile housing as described in Section 6;
- Lay the cover on a flat steady surface;
- Inspect the resetting mechanism (a pusher, springs and a roller), optic sensors and a damper (Ref. Fig. 10);
- Remove dust from a rotation sensor disc, located in the spacing of the rotation optic sensors, with alcohol-gasoline blend applied with a cloth. Avoid ingress of dust into the operational spacing of the optic sensors;
- Lubricate with machine oil:
  - four bushes of the resetting mechanism (two – on the rotation axis of the pusher, two – on the fastening axis of the springs as well as holes in the fastening parts of the springs); 2-3 drops of oil in each lubrication point (lubrication points are marked in Figure 10). Avoid ingress of lubricant on the rotation sensor disc and the roller surfaces.
  - lock cylinders of the mechanical release lock (7) and top cover lock (4) from a side of the keyhole (4);
- Check reliability of the cable connections to the CLB connector blocks and if necessary tighten the cable fixing screws;
- Check reliability of the barrier arm (5) fastening, to do so:
  - unscrew the cover (6) screw M4x25 with a screw driver and take off the cover (6);
  - tighten the M8x30 bolts of the barrier arms with the S13 socket wrench if necessary;
  - put the cover into its operating position and fix it with the screw.
- Check reliability of the turnstile housing fastening to the floor and if necessary, tighten the anchor bolts with S17 socket wrench.

### TB-01 Electromechanical box tripod turnstile with two built-in readers

- Return the top cover (3) into its operating position (Ref. Section 6); mounting of the housing top cover does not need much efforts: the top cover lock locks by pressing the lock cylinder without turning the key.
- Check operation of the TB-01 turnstile in accordance with Section 9 of this Manual.

After maintenance works are complete the turnstile is ready for further operation.

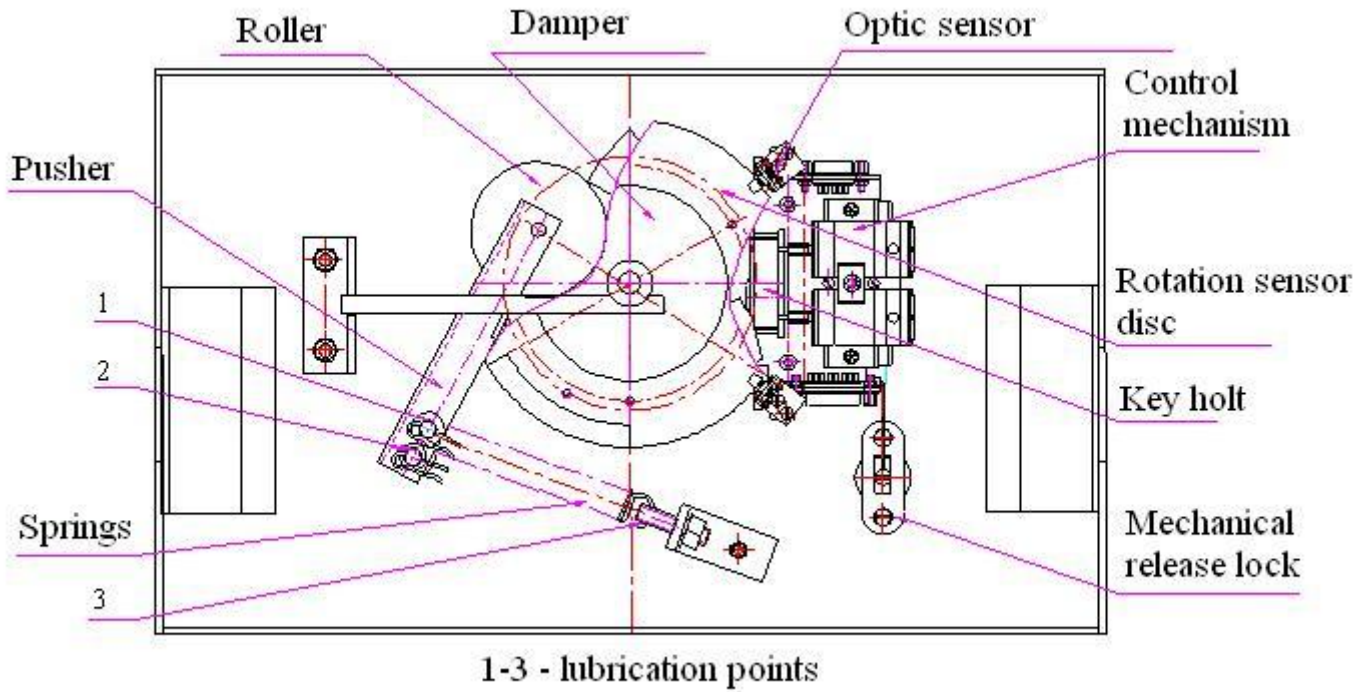

**Figure 10 – Interior components of the TB-01 turnstile mechanism**

In case of any defects revealed during visual check please apply to the PERCo Technical Support Department (the PERCo TSD).

APPENDIX A

CONNECTION LAYOUT OF THE TB-01 TURNSTILE AND OPTIONAL EQUIPMENT

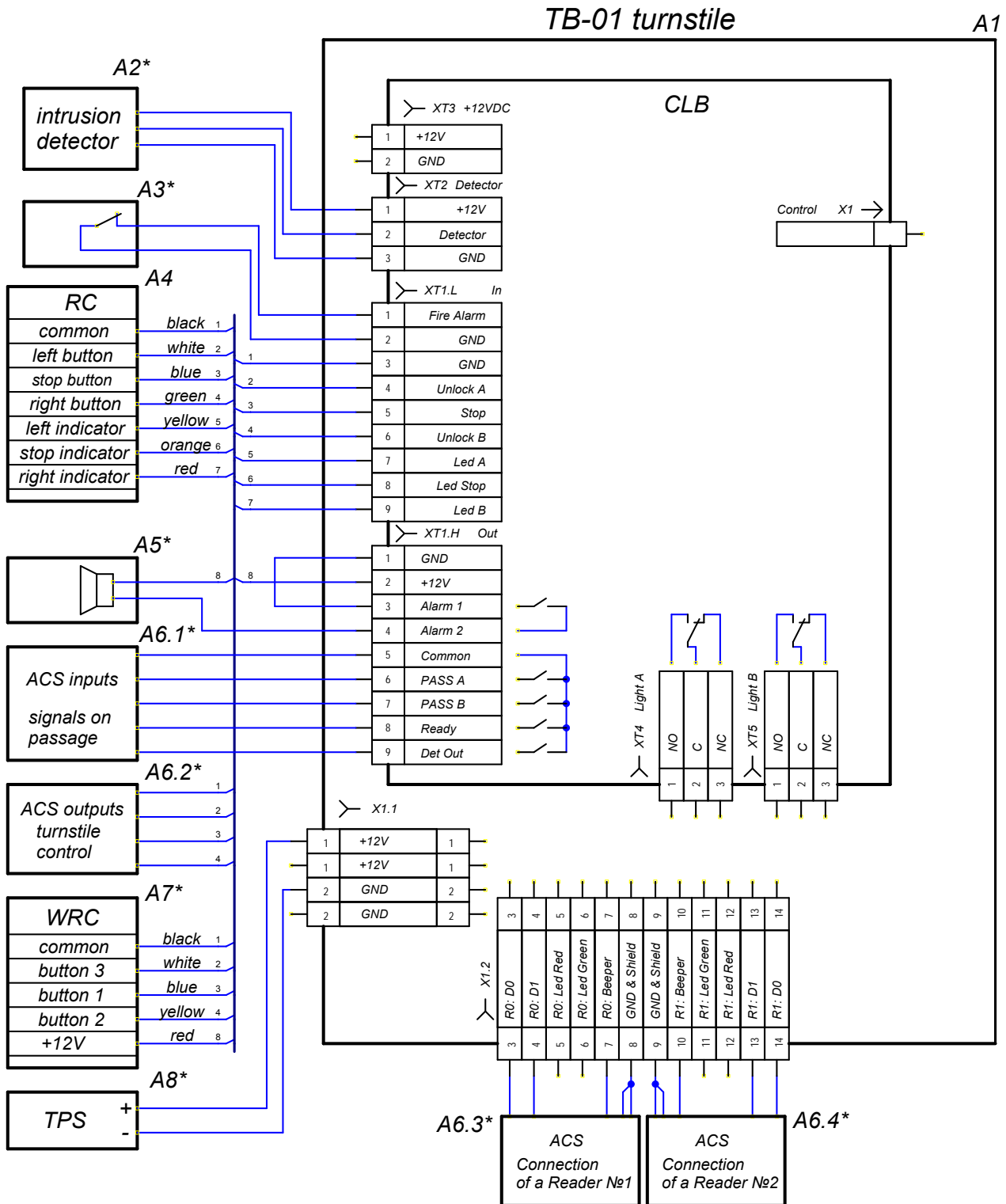

Figure A.1 – Connection layout of the TB-01 turnstile and optional equipment\*

\* Elements of the scheme are listed in Table A.1.

Table A.1

Elements of the connection layout

| Legend  | Name                                  | Q-ty | Note               |
|---|---------------------------------------|------|--------------------|
| A1  | Bracket with CLB and connector blocks | 1    |                    |
| A2*   | Intrusion detector                    | 1    | <i>CLIP-4</i>      |
| A3*   | Emergency unblocking device           | 1    |                    |
| A4  | Remote control panel                  | 1    |                    |
| A5*   | Siren                                 | 1    |                    |
| A6*   | Access control system                 | 1    |                    |
| A7*   | Wireless remote control               | 1    | <i>MSRF-4</i>      |
| A8*   | Turnstile power supply unit           | 1    | <i>12 V, 1,5 A</i> |
| X1.1  | Connector block                       | 1    |                    |
| X1.2  | Connector block                       | 1    |                    |
| * This equipment is not included in standard delivery set |                                       |      |                    |

RC – remote control panel;  
 WRC – wireless remote control;  
 TPS – turnstile power supply;  
 ACS – access control system.

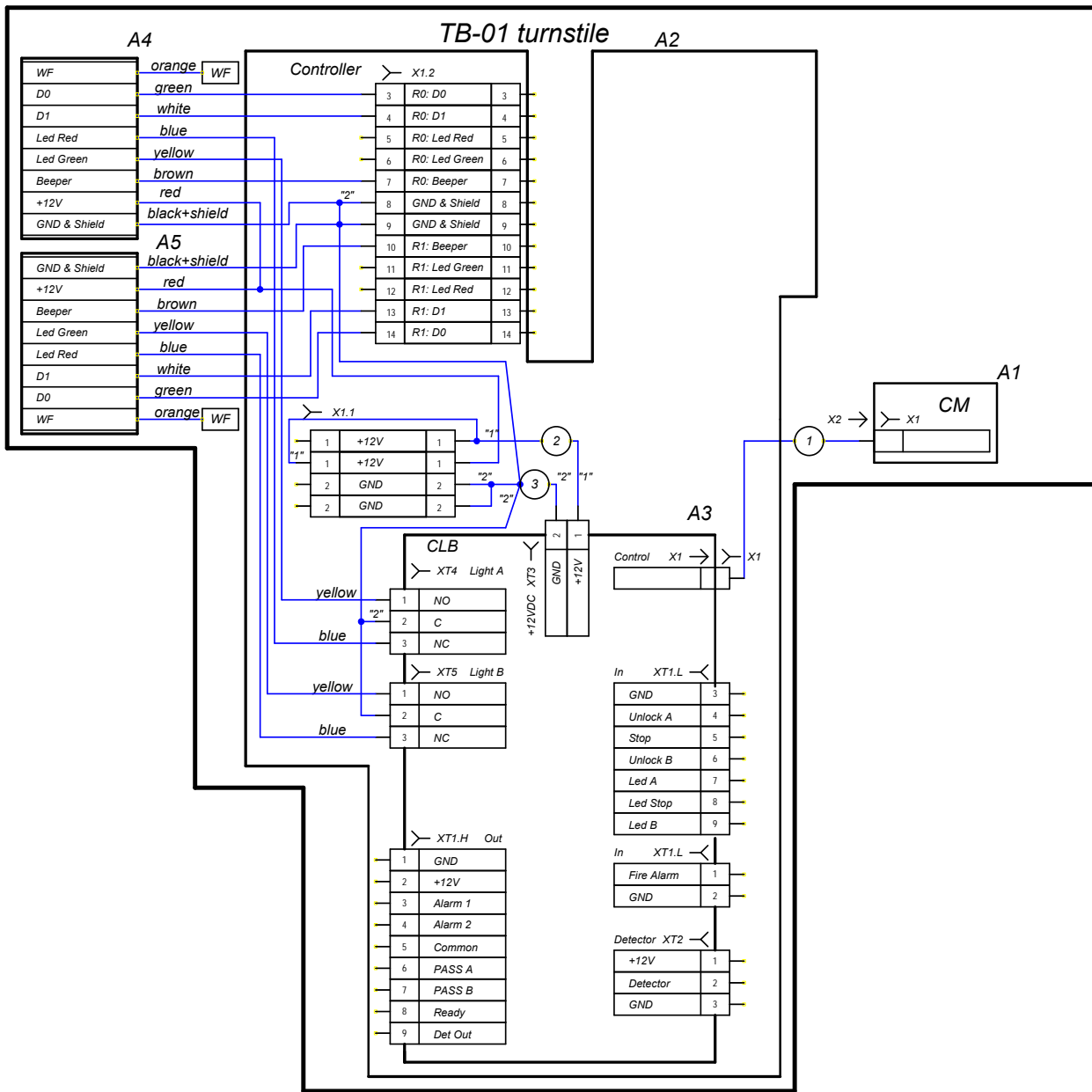

Figure A.2 – TB-01 internal connections layout

**Table A.2****Elements of the internal connections layout**

| <b>Legend</b> | <b>Name</b>                           | <b>Q-ty</b> | <b>Note</b> |
|---------------|---------------------------------------|-------------|-------------|
| A1            | Control mechanism TTR-06.140.00       | 1           |             |
| A2            | Bracket with CLB and connector blocks | 1           |             |
| A3            | CLB                                   | 1           |             |
| A4            | Cover TBC01.150.00 (with a reader)    | 1           | №1          |
| A5            | Cover TBC01.150.00 (with a reader)    | 1           | №2          |
| X1.1          | Connector block                       | 1           |             |
| X1.2          | Connector block                       | 1           |             |
| 1             | Turnstile cable TTR-04.1.900.00       | 1           |             |
| 2             | Cable TB-01.112.00 (power)            | 1           |             |
| 3             | Cable TB-01.113.00 (common cable)     | 1           |             |
|               |                                       |             |             |

CM – control mechanism;

WF – Wiegand-Format – change of outgoing data format of Wiegand interface.

## APPENDIX B

### CONTROL SIGNAL ALGORITHM IN PULSE CONTROL MODE

The command is a signal active front (signal transfer from the high level to the low level) at any of the contacts at presence of the corresponding signal levels at the other contacts. The following commands can be formed by sending a low-level signal to the contacts “Unlock A”, “Stop” and “Unlock B” of the “XT1.L” connector block relatively to the contact “GND”:

#### **Always locked (locked for entry and exit)**

Active front is at the contact “Stop” while there is a high level at the contacts “Unlock A” and “Unlock B”.

Both passage directions are locked at this command.

#### **Single passage in the direction A (open for passage of one person in the direction A)**

Active front is at the contact “Unlock A” while there is a high level at the contacts “Stop” and “Unlock B”.

At this command the passage direction A opens either for 5 sec. or until the passage has been made in this direction or until the command “Always locked”, and the status of the passage direction B does not change at that. The command is ignored if at the moment of its receipt the status of the passage direction A is “Always free”.

#### **Single passage in the direction B (open for passage of one person in the direction B)**

Active front is at the contact “Unlock B” while there is a high level at the contacts “Stop” and “Unlock A”.

At this command the passage direction B opens either for 5 sec. or until the passage has been effected in this direction or until the command “Always locked”, and the status of the passage direction A does not change. The command is ignored if at the moment of its receipt the status of passage direction B is “Always free”.

#### **Bi-directional single passage (open for one passage in each direction)**

Active front is at the contact “Unlock A” while there is a low level at the contact “Unlock B” and a high level at the contact “Stop”,

or active front is at the contact “Unlock B” while there is a low level at the contact “Unlock A” and a high level at the contact “Stop”.

At this command the both passage directions open either for 5 sec. each or until the command “Always locked” is received. The command is ignored for the passage direction, which status at the moment of its receipt is “Always free”.

#### **Free passage in the direction A (open for free passage in the direction A)**

Active front is at the contact “Unlock A” while there is a low level at the contact “Stop” and a high level at the contact “Unlock B”,

or active front is at the contact “Stop” while there is a low level at the contact “Unlock A” and a high level at the contact “Unlock B”.

At this command the passage direction A opens until the command “Always locked” is received; the status of the passage direction B does not change at that.

#### **Free passage in the direction B (open for free passage in the direction B)**

## **TB-01 Electromechanical box tripod turnstile with two built-in readers**

Active front is at the contact “Unlock B” while there is a low level at the contact “Stop” and a high level at the contact “Unlock A”,  
or active front is at the contact “Stop” while there is a low level at the contact “Unlock B” and a high level at contact “Unlock A”.

At this command the passage direction B opens until the command “Always locked” is received; the status of the passage direction A does not change at that.

### **Free passage (open for free passage in both directions)**

Active front is at the contact “Unlock A” while there is a low level at the contacts “Unlock B” and “Stop”,  
or active front is at the contact “Unlock B” while there is a low level at the contacts “Unlock A” and “Stop”,  
or active front is at the contact “Stop” while there is a low level at the contacts “Unlock A” and “Unlock B”.

The both directions open at this command until the command “Always locked” is received.

**Note!** For the remote control panel:

- active front – pressing of the relevant button on the remote control panel;
- low level – the relevant button on the remote control panel has been pressed;
- high level – the relevant button on the remote control panel is not pressed.

## APPENDIX C

### CONTROL SIGNAL ALGORITHM IN POTENTIAL CONTROL MODE

#### **Both directions are locked (locked for entry and exit)**

There is a high level at the contacts “Unlock A” and “Unlock B”, or a low level at the contact “Stop”.

The both passage directions lock at this command.

#### **The direction A is open (open for passage in the direction A)**

There is a low level at the contact “Unlock A” while a high level is present at the contacts “Stop” and “Unlock B”.

At this command the direction A opens till the low-level signal removal from the contact A or until the command “Both directions locked” is received. The status of the direction B does not change at that.

#### **The direction B is open (open for passage in the direction B)**

There is a low level at the contact “Unlock B” while there is a high level at the contacts “Stop” and “Unlock A”.

At this command the direction B opens till the low-level signal removal from the contact B or until the command “Both directions locked” is received. The status of the direction A does not change at that.

#### **Both directions are open (open for entry and exit)**

There is a low level at the contacts “Unlock A” and “Unlock B” while there is a high level at the contact “Stop”.

The both directions open at this command till the low-level signal removal from one of the contacts A (B) or until the command “Both directions locked” is received.

**Note!** For ACS controller outputs:

- low level      – either contacts of the output relay are closed or the output transistor is open;
- high level     – either contacts of the output relay are broken or the output transistor is closed.



